

MACHINES

# APR VIBRATORY PLATES

APR SERIES REVERSIBLE  
VIBRATORY PLATES



**AMMANN**



# THE RIGHT FIT ON YOUR JOBSITE

## AMMANN APR REVERSIBLE VIBRATORY PLATES

These machines offer outstanding compaction performance and are among the fastest in their class. APR vibratory plates work reliably, even on uneven terrain and difficult compaction surfaces, thanks to their carefully balanced components. With the availability of wide models, the APR series from Ammann has the right machine for any application.



### APR 2220 PETROL

WEIGHT: 100 kg (220 lb)  
WORKING WIDTH:  
400 mm (15.7 in)  
MAX. VIBRATING FREQUENCY:  
98 Hz (5880 vpm)  
MAX. CENTRIFUGAL FORCE:  
22 kN (4.9 lfb)



### APR 2620

WEIGHT: 130 / 135 kg (287 / 298 lb)  
WORKING WIDTH:  
380/500 mm (15.9/19.7 in)  
MAX. VIBRATING FREQUENCY:  
95 Hz (5700 vpm)  
MAX. CENTRIFUGAL FORCE:  
24 kN (5.4 lfb)



### APR 3020 PETROL

WEIGHT: 199 / 205 kg (438.7 / 451.9 lb)  
WORKING WIDTH:  
500/600 mm (19.7/23.6 in)  
MAX. VIBRATING FREQUENCY:  
90 Hz (5400 vpm)  
MAX. CENTRIFUGAL FORCE:  
30 kN (6.7 lfb)



### APR 2220 DIESEL

WEIGHT: 121 / 128 kg (266 / 282 lb)  
WORKING WIDTH:  
400 / 500 mm (15.7 / 19.7 in)  
MAX. VIBRATING FREQUENCY:  
98 Hz (5880 vpm)  
MAX. CENTRIFUGAL FORCE:  
22 kN (4.9 lfb)



### APR 3020 DIESEL

WEIGHT: 199 / 205 kg (468 / 477 lb)  
WORKING WIDTH:  
500 / 600 mm (19.7 / 23.6 in)  
MAX. VIBRATING FREQUENCY:  
90 Hz (5400 vpm)  
MAX. CENTRIFUGAL FORCE:  
30 kN (6.7 lfb)



### APR 3520 PETROL

WEIGHT: 242 / 257 kg (533 / 566 lb)

WORKING WIDTH:  
600 mm (23.6 in)

MAX. VIBRATING FREQUENCY:  
65 Hz (3900 vpm)

MAX. CENTRIFUGAL FORCE:  
38 kN (8.5 lbf)



### APR 3520 DIESEL

WEIGHT: 257 / 271 kg (266.6 / 597.5 lb)

WORKING WIDTH:  
600 mm (23.6 in)

MAX. VIBRATING FREQUENCY:  
65 Hz (3900 vpm)

MAX. CENTRIFUGAL FORCE:  
38 kN (8.5 lbf)



### APR 4920

WEIGHT: 391–424 kg (862– 934.8 lb)

WORKING WIDTH:  
450 / 600 / 750 mm (17.7 / 23.6 / 29.5 in)

MAX. VIBRATING FREQUENCY:  
65 Hz (3900 vpm)

MAX. CENTRIFUGAL FORCE:  
49 kN (11 lbf)



### APR 5920

WEIGHT: 440–473 kg (970– 1047.2 lb)

WORKING WIDTH:  
450 / 600 / 750 mm (17.7 / 23.6 / 29.5 in)

MAX. VIBRATING FREQUENCY:  
65 Hz (3900 vpm)

MAX. CENTRIFUGAL FORCE:  
59 kN (13 lbf)

# YOUR BENEFITS AT A GLANCE

WHAT CHARACTERISES THE REVERSIBLE  
VIBRATORY PLATES FROM AMMANN?

## EFFICIENCY

### Powerful machines

High compaction forces deliver the best compaction results.

### Optimised base plate

Design enables higher speed and therefore faster coverage;  
rear is thicker for long life and cost efficiency.

### Hydraulic forward and reverse drive

Provides simple and precise machine control  
even in confined spaces.

### Optional paving pad

For careful work on paving blocks.

## ERGONOMICS

### Low-vibration guide handle

Industry-leading HAV values below 2.5 m/sec<sup>2</sup> protect operator and  
eliminate need for time-consuming record keeping.

### Open guide handle

Optimises manoeuvrability and prevents damage.

### Central single-point suspension

Enhances safety through simple transport.

## SERVICEABILITY

### Low-wear exciter unit

Extended service intervals reduce customer service costs.

### Simplified maintenance work

QR codes show proper maintenance in shortest time.

### Water separator

Standard feature reduces jobsite downtime.







# WORK WITH CONFIDENCE AND MAXIMUM PRECISION

HANDLE IS THE KEY TO MACHINE'S SUCCESS

## HYDROSTATIC STEERING

The hydrostatic forward and reverse steering of APR plates allows for quick directional changes and the ability to compact in tight and hard-to-reach spaces.

## BUILT-IN SAFETY

The intuitive handle improves safety by reducing HAV values below  $2.5 \text{ m/sec}^2$  while also enabling precise control. The operator simply pushes or pulls the handle to engage the machine in forward or reverse. No separate controls or steering are required.

## BUILT-IN EFFICIENCY

The hydrostatic setting enables "on-the-spot" vibration in particularly challenging areas. The machine essentially hovers – no forward or reverse movement is required – while providing maximum compaction output that enables quick results.

## BUILT-IN DURABILITY

A robust compaction frame protects the plate from tough jobsites or improper use. The open design grants easy access for service and machine operation, ensuring the proper maintenance is undertaken to maximise machine life. The centrifugal clutch and wear resistant V belt are well protected by an additional cover that keeps out water and dirt.

## INDUSTRY-LEADING LOW HAV LEVELS

An innovative handle concept lowers the hand-arm vibration (HAV) values on Ammann APR plates to a level of less than  $2.5 \text{ m/sec}^2$ , eliminating health risks to the operator and making work more convenient and safer.

- + better machine control
- + reduced operator fatigue
- + optimal operator health and safety

## INTUITIVE OPERATION AND SAFETY

The handle provides ideal grip and enables simple, intuitive machine operation by simply pushing or pulling. The open design of the handle prevents machine damage that can result from accidental lifting. The handle folds for easy transport.

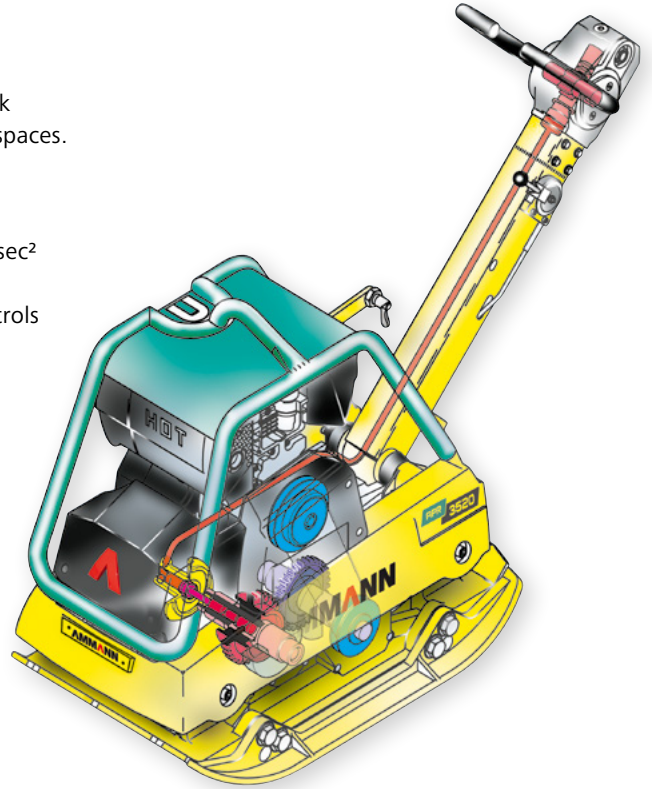





“The APR’s powerful amplitude provides industry-leading compaction results. Safety is built into the plate through a vibration-limiting handle that significantly reduces HAV impact on the operator.”

AMMANN

AMMANN



# ADDED VALUE

## OPTIONS FOR YOUR APR PLATE

Quality and productivity are prerequisites for construction machines. Ammann machines offer both and stand out through ease of operation, too. Numerous options ensure all customers have the ideal machine for their needs.

### ELECTRIC STARTER

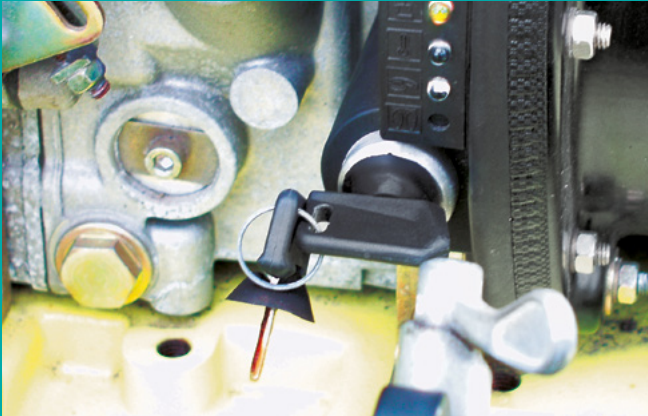

APR models with a diesel engine can be equipped with an optional electric start for an effortless beginning to every shift.

### TRANSPORT WHEELS



Permanently installed transport wheels are available for APR 2220, APR 2620 and APR 3020 models. The wheels are mounted in a safe position behind the plate and simply unfold beneath the machine when needed.

### UPGRADE QUICKLY TO SUCCEED ON PAVING STONES



Contractors can protect paving stones without losing production time thanks to a toolless, mountable rubber pad that covers the base plate. The pad prevents the paving stones from becoming chipped, cracked or scratched and can be installed on the jobsite in a matter of seconds. This leads to greatly reduced handling costs and to more flexible and efficient machine utilisation.

Slings on all four corners allow the pad to be pulled over the edges of the base plate. While simple to install, the pad maintains a firm grip and does not move during the compaction process.



## AMMANN SERVICELINK



This comprehensive service reduces handling and logistical costs through efficient monitoring of battery charging status. Machine utilisation, including the hours and days operated, also is displayed. Servicelink also serves as a planning tool by providing service status overviews.

## HOURS-RUN METER



The next service date can be scheduled well in advance thanks to a continuous display of hours run.



# APR 2220

# APR 2620

## REVERSIBLE VIBRATORY PLATE

### A FAST WORKER AND A GOOD CLIMBER

The low weight and narrow working width make the APR 2220 and APR 2620 the ideal compactors for confined spaces or when working in garden- landscaping applications.

With a working width of just 40 cm and a weight of around 100 kg, APR 2220 navigates even the tightest spaces. Even difficult tasks are easy to handle thanks to its compact design and extensive manoeuvrability.

A working width of 38 cm or 50 cm makes the APR 2620 ideal for many different purposes. The versatile machine puts on a convincing show in different areas.

### WATER SPRINKLER ENABLES ACTIONS ON ASPHALT

The APR 2620 is available with an optional sprinkler system for working on bituminous surfaces, making the plate even more versatile in use.



### HIGHLIGHTS

- Operator friendly, safety-optimised guide handle that reduces HAV values below 2.5 m/sec<sup>2</sup> and folds for easy transport
- Infinitely adjustable hydraulic forward and reverse drive including spot vibration for compacting especially demanding substrates
- Simple ergonomic handling
- Maintenance-friendly twin-shaft exciter with long service intervals and a long life-span
- Wear-resistant, self-cleaning base plate
- Well-protected, robust centrifugal clutch with wear-resistant V belt
- Robust protective frame with central single-point suspension
- Powerful petrol or diesel engine
- Other options include a Vulkollan plate, hours-run meter and transport wheels





# APR 3020

# APR 3520

## REVERSIBLE VIBRATORY PLATE

### DEVELOPED FOR HIGHEST PRODUCTIVITY

The APR 3020 & APR 3520 vibratory plates are easy to use and ideal for any application – from small areas to larger surfaces. Their working width of 50–60 cm and their large compaction forces make these machines economical when it comes to compacting small and larger surface areas.

### ALSO IDEAL FOR PAVING BLOCKS

The APR 3520 is the preferred vibratory plate for laying paving stones with thicknesses of up to 10 cm.

The optionally available paving pad protects the stones from damage during compaction. The toolless mountable paving pad allows for a quick change of the applications, without any need to stop at the workshop for assembling.



### HIGHLIGHTS

- Operator friendly, safety-optimised guide handle that reduces HAV values below 2.5 m/sec<sup>2</sup> and folds for easy transport
- Infinitely adjustable hydraulic forward and reverse drive including spot vibration for compacting especially demanding substrates
- Simple ergonomic handling
- Maintenance-friendly twin-shaft exciter with long service intervals and a long life-span
- Wear-resistant, self-cleaning base plate
- Well-protected, robust centrifugal clutch with wear-resistant V belt
- Robust protective frame with central single-point suspension
- Powerful petrol or diesel engine
- Other options include a Vulkollan plate, hours-run meter and transport wheels
- An electric starter is available for machines powered by a Hatz diesel engine



# APR 4920 & APR 5920

## REVERSIBLE VIBRATORY PLATES

### THE SUPERIOR CLASS OF MECHANICALLY REVERSIBLE VIBRATORY PLATES

Both models have an ideal weight distribution between the upper and lower sections and a powerful vibration unit for the best compaction results.

#### OPTIMUM PROTECTION

Component protection is a key feature. The engine and other functional parts built into the upper section are well protected by a folding hood that also provides easy access during maintenance work.

#### FLEXIBILITY IN EVERY APPLICATION

Options such as an electric start, attachment angles and Vulkollan mats increase flexibility and make these plates the ideal machines for plant hire services, construction companies and landscape gardeners.

#### HIGHLIGHTS

- Operator friendly, safety-optimised guide handle that reduces HAV values below 2.5 m/sec<sup>2</sup> and folds for easy transport
- Infinitely adjustable hydraulic forward and reverse drive including spot vibration for compacting especially demanding substrates
- Simple ergonomic handling
- Maintenance-friendly twin-shaft exciter with long service intervals and a long life-span
- Wear-resistant, self-cleaning base plate
- Well-protected, robust centrifugal clutch with wear-resistant V belt
- Powerful diesel engine
- Other options include a Vulkollan plate for compacting asphalt, an hours-run meter and an electric start
- Attachment angles of 75 mm and 150 mm

#### ACE COMPACTION EXPERT – BIG TECHNOLOGY IN A SMALL PACKAGE

APR Reversible Vibratory Plates can be equipped with the well known Ammann Compaction Expert (ACE), an automated compaction measurement and control system.

The ACE system on the vibratory plates utilises the well developed technology used in Ammann's heavy compaction machines for years. It provides operators with an accurate indication of soil stiffness and whether desired compaction has been achieved.

#### The benefits of ACE technology are significant:

1. It can reduce the number of passes a plate compactor makes, therefore delivering savings on fuel, labour and machine wear.
2. ACE helps ensure proper compaction is achieved and prevents costly rework.
3. It extends the life of the compacted material – and structures placed on top of it – by providing a homogenous surface without weak spots.

#### HIGHLIGHTS ACE<sup>econ</sup>

- Relative compaction measuring device
- Provides continuous information about compaction levels
- Evaluates when maximum compaction has been reached

**ACE<sup>econ</sup> available on APR 4920 and APR 5920**







### APR 4920

The agile APR 4920 has an engine output of 6.6 kW as well as good gradeability and compaction performance. The machine can handle inclines of up to 30%.

The APR 4920 counts alongside the APR 5920 as one of the most powerful vibratory plates in its class.

Its working width of 450 mm is extendible using add-on plates of 75 mm or 150 mm. The robust engine hood protects the engine and provides easy access to all service points.



### APR 5920

This reversible vibratory plate stands out through its manoeuvrability and gradeability that enable it to work on slopes with an incline of up to 30%. The machine is driven by a powerful diesel engine. The vibratory plate can handle difficult and hard-to-reach areas thanks to its infinitely adjustable forward and reverse drive. Optional attachment angles with a width of 75 mm or 150 mm increase productivity.

### VARIED WEIGHTS

Options such as an electric starter (weighs 7 kg) and attachment plates enable customers to adapt the machines to a jobsite's specific challenges. The result: A machine that performs at the level of a 500 kg vibratory plate, a common class size worldwide.



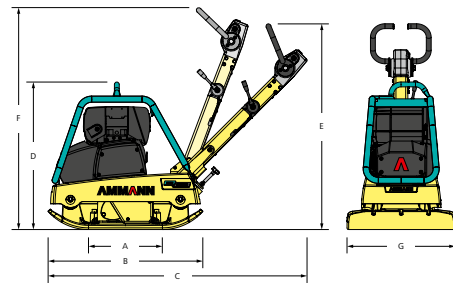

## DIMENSIONS & WEIGHT

	APR 2220 Petrol	APR 2220 Diesel	APR 2620 Diesel	APR 3020 Petrol	APR 3020 Diesel	APR 3520 Petrol	APR 3520 Diesel
MACHINE WEIGHT	100 kg (220 lb)	121 / 128 kg (266 / 282 lb)	130 / 135 kg (287 / 298 lb)	199 / 205 kg (438.7 / 451.9 lb)	213 / 217 kg (468 / 477 lb)	242 / 257 kg (533 / 566 lb)	257 / 271 kg (266.6 / 597.5 lb)
A BASE PLATE LENGTH	254 mm (10.0 in)	254 mm (10.0 in)	330 mm (13.0 in)	330 mm (13.0 in)	330 mm (13.0 in)	410 mm (16.1 in)	410 mm (16.1 in)
B MACHINE LENGTH	620 mm (24. in)	620 mm (24.4 in)	700 mm (27.6 in)	700 mm (27.6 in)	700 mm (27.6 in)	860 mm (33.9 in)	860 mm (33.9 in)
C WITH GUIDE HANDLE	1140 mm (44.9 in)	1140 mm (44.9 in)	1140 mm (44.9 in)	1140 mm (44.9 in)	1140 mm (44.9 in)	1365 mm (53.7 in)	1365 mm (53.7 in)
D MACHINE HEIGHT	610 mm (24.0 in)	730 mm (28.7 in)	740 mm (29.1 in)	740 mm (29.1 in)	740 mm (29.9 in)	750 mm (29.5 in)	780 mm (30.9 in)
E GUIDE HANDLE HEIGHT (WORK)	1000 mm (39.4 in)	1000 mm (39.4 in)	1000 mm (39.4 in)	1000 mm (39.4 in)	1000 mm (39.4 in)	1000 mm (39.4 in)	1000 mm (39.4 in)
F GUIDE HANDLE HEIGHT (TRANSFER)	1180 mm (46.5 in)	1180 mm (46.5 in)	1180 mm (46.5 in)	1180 mm (46.5 in)	1180 mm (46.5 in)	1180 mm (44.9 in)	1180 mm (44.9 in)
G MACHINE WIDTH	400 mm (15.7 in)	400/500 mm (15.7 / 19.7 in)	380/500 mm (15.9 / 19.7 in)	500 / 600 mm (19.7 / 23.6 in)	500 / 600 mm (19.7 / 23.6 in)	600 mm (23.6 in)	600 mm (23.6 in)

## ENGINE

ENGINE	Honda GX 120	Hatz 1 B 20	Hatz 1 B 20	Honda GX 270	Hatz 1 B 30	Honda GX 270	Hatz 1 B 30
FUEL	Petrol	Diesel	Diesel	Petrol	Diesel	Petrol	Diesel
OUTPUT	4 HP / 2.9 kW	4.2 HP / 3.1 kW	4.2 HP / 3.1 kW	8.6 HP / 6.3 kW	6.1 HP / 4.5 kW	8.6 HP / 6.3 kW	6.3 HP / 4.6 kW
RPM	3600	3000	3000	3100	2900	3100	3000
CONSUMPTION	0.9 l/h (0.2 gal/h)	0.9 l/h (0.2 gal/h)	0.9 l/h (0.2 gal/h)	2.1 l/h (0.5 gal/h)	1.3 l/h (0.3 gal/h)	2.1 l/h (0.5 gal/h)	1.3 l/h (0.3 gal/h)

## COMPACTION OUTPUT

MAX. VIBRATION FREQUENCY	98 Hz (5800 vpm)	98 Hz (5800 vpm)	95 Hz (5700 vpm)	90 Hz (5400 vpm)	90 Hz (5400 vpm)	65 Hz (3900 vpm)	65 Hz (3900 vpm)
MAX. CENTRIFUGAL FORCE	22 kN (4.9 lfb)	22 kN (4.9 lfb)	24 kN (5.4 lfb)	30 kN (6.7 lfb)	30 kN (6.7 lfb)	38 kN (8.5 lfb)	38 kN (8.5 lfb)
WORKING SURFACE	600 m <sup>2</sup> /h (6458 ft <sup>2</sup> /h)	600 m <sup>2</sup> /h (6458 ft <sup>2</sup> /h)	524 m <sup>2</sup> /h (5640 ft <sup>2</sup> /h)	660 m <sup>2</sup> /h (7104 ft <sup>2</sup> /h)	660 m <sup>2</sup> /h (7104 ft <sup>2</sup> /h)	936 m <sup>2</sup> /h (10075 ft <sup>2</sup> /h)	936 m <sup>2</sup> /h (10075 ft <sup>2</sup> /h)
WITH ATTACHMENT ANGLES	-	690 m <sup>2</sup> /h (7427 ft <sup>2</sup> /h)	630 m <sup>2</sup> /h (6781 ft <sup>2</sup> /h)	720 m <sup>2</sup> /h (7750 ft <sup>2</sup> /h)	720 m <sup>2</sup> /h (7750 ft <sup>2</sup> /h)	-	-
MAX. COMPACTION DEPTH**	20 cm (7.9 in)	25 cm (9.8 in)	30 / 25 cm (11.8 / 9.8 in)	35 / 30 cm (13.8 / 11.8 in)	35 / 30 cm (13.8 / 11.8 in)	50 cm (19.7 in)	50 cm (19.7 in)

## MISCELLANEOUS

WORKING SPEED	0-25 m/min	0-25 m/min	0-23/21 m/min	0-22/20 m/min	0-22/20 m/min	0-26 m/min	0-26 m/min
FUEL TANK	2.5 l (0.6 gal)	3 l (0.7 gal)	3 l (0.7 gal)	6 l (1.3 gal)	5 l (1.1 gal)	6 l (1.3 gal)	5 l (1.1 gal)
WATER TANK	-	-	7.5 l (2.1 gal)	-	-	-	-
MAX. GRADEABILITY	35%	35%	35%	35%	35%	35%	35%
MAX. INCLINE	20°	30°	30°	20°	30°	20°	30°

## OPTIONS

TRANSPORT WHEELS	x	x	x	x	x	-	-
PAVING PAD	x	x	x	x	x	x	x
E-START	-	-	-	x	x	x	x
HOUR METER	x	x	x	x	x	x	x
WATER SPRINKLER	-	-	x	-	-	-	-

\*\* Depending on ground conditions



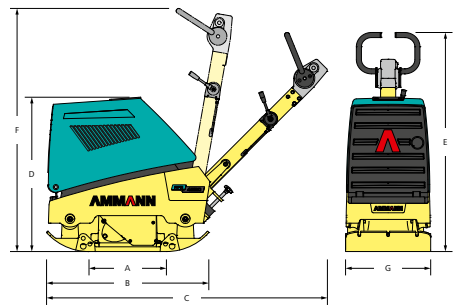

## DIMENSIONS & WEIGHT

	APR 4920	APR 5920
MACHINE WEIGHT	391 kg (862.0 lb)	440 kg (970 lb)
WITH ATTACHMENT ANGLE 75 mm	413 kg (910.5 lb)	461 kg (1016.3 lb)
WITH ATTACHMENT ANGLE 150 mm	424 kg (934.8 lb)	473 kg (1047.2 lb)
A BASE PLATE LENGTH	450 mm (17.7 in)	450 mm (17.7 in)
B MACHINE LENGTH	898 mm (35.4 in)	898 mm (35.4 in)
C WITH GUIDE HANDLE	1485 mm (58.5 in)	1453 mm (57.2 in)
D MACHINE HEIGHT	817 mm (32.2 in)	850 mm (33.5 in)
E GUIDE HANDLE HEIGHT (WORK)	1000 mm (39.4 in)	1000 mm (39.4 in)
F GUIDE HANDLE HEIGHT (TRANSFER)	1285 mm (50.6 in)	1285 mm (50.6 in)
G MACHINE WIDTH	450 / 600* / 750 mm (17.7 / 23.6* / 29.5 in)	450 / 600* / 750 mm (17.7 / 23.6* / 29.5 in)

## ENGINE

ENGINE	Hatz 1B40	Hatz 1B40
FUEL	Diesel	Diesel
OUTPUT	9 HP / 6.6 kW	9 HP / 6.6 kW
RPM	2900	2900
CONSUMPTION	1.6 l/h (0.4 gal)	1.6 l/h (0.4 gal)

## COMPACTION OUTPUT

MAX. VIBRATION FREQUENCY	65 Hz (3900 vpm)	65 Hz (3900 vpm)
MAX. CENTRIFUGAL FORCE	49 kN (11 lbf)	59 kN (13 lbf)
WORKING SURFACE	945m <sup>2</sup> /h (10171 ft <sup>2</sup> /h)	945m <sup>2</sup> /h (10171 ft <sup>2</sup> /h)
WITH ATTACHMENT ANGLE 75 mm	1080 m <sup>2</sup> /h (2325 ft <sup>2</sup> /h)	1080 m <sup>2</sup> /h (2325 ft <sup>2</sup> /h)
WITH ATTACHMENT ANGLE 150 mm	1350 m <sup>2</sup> /h (2874 ft <sup>2</sup> /h)	1350 m <sup>2</sup> /h (2874 ft <sup>2</sup> /h)
MAX. COMPACTION DEPTH **	60 cm (24 in)	70 cm (28 in)

## MISCELLANEOUS

WORKING SPEED	35 m/min (1.3 mph)	35 m/min (1.3 mph)
FUEL TANK	5 l (1.1 gal)	5 l (1.1 gal)
MAX. GRADEABILITY	30 %	30 %
MAX. INCLINE	25°	25°

## OPTIONS

TRANSPORT WHEELS	-	-
PAVING PAD	x	x
E-START	x	x
HOUR METER	x	x
ACE <sup>econ</sup>	x	x
AMMANN SERVICELINK	Standard	Standard
ATTACHMENT ANGLES (75 / 150 mm)	x	x

\* Standard working width \*\* Depending on ground conditions

# SERVICE

## A NETWORK TO SUPPORT YOU

No matter where you are, Ammann-trained technicians and parts are nearby. Ammann dealers provide well-trained service technicians who can help you, whether it's an emergency or time for preventive maintenance. The vast Ammann network ensures there is a nearby technician who understands your language and your technical needs. Parts availability and ease of ordering are always Ammann priorities.

### SERVICE APP

The service app for Ammann machines impresses machine operators who are already benefiting from the advantages of the free application. The easy-to-use app provides machine operators working on site quick and uncomplicated access to machine documentation.

### SERVICE VIDEOS

Sometimes a video tells the story best. That's why you'll find a variety of service videos that walk you through service and maintenance processes.

### QR CODE

Many maintenance kits feature QR codes that link to videos with helpful demonstrations that walk you or your technician through the process. The videos tell the story without dialogue so customers anywhere in the world can understand.





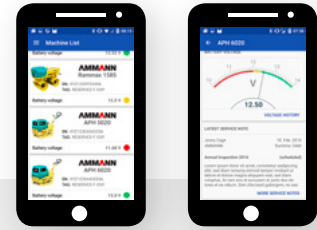

## SERVICELINK THE SIMPLE AND EFFICIENT WAY TO CONNECT TO YOUR MACHINES

### Fleet management made easy

ServiceLink enables you to keep an eye on all of your machines and their status at any time. You can see all the relevant information regarding maintenance, battery status and warranty period with one click. You also can easily manage your machines via an app or online.

## MACHINE DATA

ServiceLink stores and transmits the latest machine data such as battery status, hours run and the number of machine starts.

## SERVICE INFORMATION

Additional data can be stored on the ServiceLink relay via the Ammann Service app or online. Save maintenance information and pending repair work directly on the machine – where it is available to your service team at any time.

## ONLINE AND MOBILE

Machine data can be accessed and edited at any time either online or through the Ammann Service app.

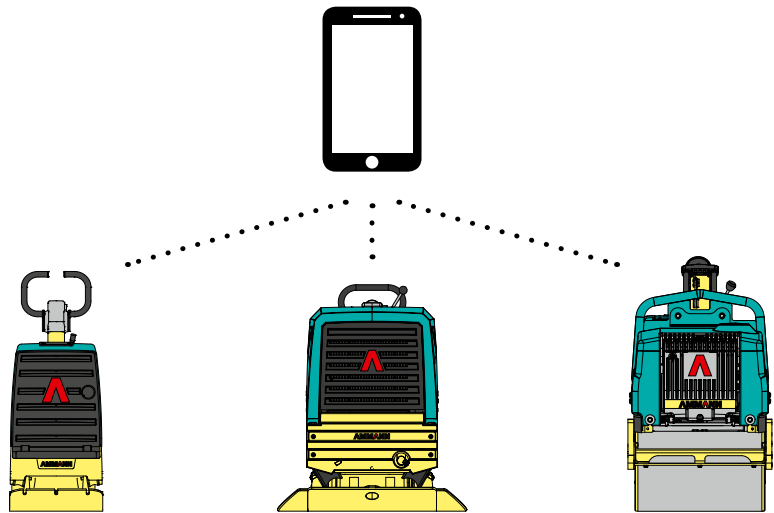

## HIGHLIGHTS

- Access to machine data via the ServiceLink web app
- Easy registration of new machines via the Ammann Service app on your smartphone
- Manage service information and save machine information
- Compatible with all battery-powered machines (including those built by other manufacturers)



# TRAINING

## ENHANCE YOUR PERFORMANCE

If Ammann machine training was summarised in a single word, it might well be “comprehensive.” The training includes multiple expertise levels and modules to benefit all skill levels.

### TRAINING WORLDWIDE

Ammann product and application experts are ready to provide the training you need, no matter where you are. The global nature of Ammann ensures an expert is always near you – ready to offer instruction that ranges from the basics to the specifics relevant to your geographic area. The training can take place at an Ammann facility, your business – or even on a jobsite.

### KEY TEACHING THEMES CONNECT ALL EFFORTS, NO MATTER WHERE THEY OCCUR

A good balance. Training often combines a traditional classroom setting with hands-on machine experience. Ammann application experts also can offer instruction on your jobsite.

Training typically includes students from other industry businesses. Participants say conversations with their peers – and learning how they overcome challenges – are other key benefits.

Learn in your language. Lessons are taught in many languages, ensuring your team understands key terms and lessons and makes the most of your training investment.





# SPARE PARTS

You can only earn money when your equipment is working. That's why Ammann does everything possible to ensure you have the parts where and when you need them. Those efforts include easy online ordering to avoid confusion and enable tracking, and efficient logistics and availability to help parts reach you quickly.

## WEARING KITS

Some machines handle abrasive materials in demanding applications. While wear is inevitable, downtime can be limited. Wearing kits make replacement of these parts efficient and cost-effective. All the necessary parts – big and small – are in a single box to keep you organised and efficient and to ensure the machines are quickly back up and running.

## EMERGENCY KITS

Emergency kits prevent little frustrations from becoming bigger issues that can shut down a machine and even a jobsite. These kits include parts such as switches, fuses and valve coils that are simple and fast to change yet still can cause significant problems if not operating properly. The kits easily fit in the trunk or bed of a vehicle so they're on hand when needed. A crew-member with a bit of technical knowledge can handle this work on the jobsite. These repairs take 2 hours or less.



## MAINTENANCE KITS

Preventive maintenance is crucial to efficient operation and service life of machines. The easier the maintenance, the more likely it is to be completed. Maintenance kits make the upkeep simple. Parts associated with a particular maintenance process are in a single box with a single part number.

## BROCHURE WITH ALL KITS

We have a prospect with all kits, and their part numbers are available for you. Just contact your parts consultant and have a digital or hardcopy sent to you.



For additional product information  
and services please visit:  
**[www.ammann.com](http://www.ammann.com)**

